

EXOcompact Second Generation (–S) Manual

DISCLAIMER

The information in this manual has been carefully checked and is believed to be correct. AB Regin however, makes no warranties as regards the contents of this manual and users are requested to report errors, discrepancies or ambiguities to Regin, so that corrections may be made in future editions. The information in this document is subject to change without prior notification.

The software described in this document is supplied under license by Regin and may be used or copied only in accordance with the terms of the license. No part of this document may be reproduced or transmitted in any form, in any fashion, electronically or mechanically, without the express, written permission of Regin.

COPYRIGHT

© AB Regin. All rights reserved.

TRADEMARKS

EXOdesigner, EXOreal, EXO4, and EXOline are registered trademarks of AB Regin.

Windows, Windows 2000, Windows XP, Windows Server 2003, and Windows Vista are registered trademarks of Microsoft Corporation.

Some product names mentioned in this document are used for identification purposes only and may be the registered trademarks of their respective companies.

November 2008

Document number: M2191

Document Revision: 2008-1-01

Table of Contents

<i>Chapter 1 Description</i>	5
Key Features	5
Range of Models	6
Single Port Models	6
Dual Port Models	7
LON Port	7
Modem Port	8
External Display	8
<i>Chapter 2 Technical Specifications</i>	9
Environmental Specifications	9
Enclosure Specifications	9
Electrical Specifications	10
Indications	12
<i>Chapter 3 Connections</i>	13
Single Port models	13
Dual Port models	14
<i>Chapter 4 Installation</i>	16
General Connections	16
With AC Supply and Mixed Loads on DO	16
With DC Supply and Mixed Loads on DO	17
I/O Description	17
EXOcompact Dual Port – Example Using Port 2 (Low Level EXOline)	19
<i>Chapter 5 Maintenance and Service</i>	20
Changing the Battery	20
Resetting the Application Memory	21
Updating EXOreal	21
Removing the Cover	22
<i>Chapter 6 External Display, ED9200</i>	24
Functions	24
Indications	25
Controller Requirements	25
Specifications	25
Connections	25
Door Mounting	26
<i>Chapter 7 External Display, ED9100</i>	27

Functions	27
Indications	27
Specifications	28
Connections & Mounting	28
<i>Chapter 8 External Display, E-DSP</i>	29
Functions	29
Indications	30
Specifications	30
Connections	30
Mounting	30
<i>Chapter 9 Appendix</i>	31
The EMC and LVD Directive	31
Declaration of Conformity	31

Chapter 1 Description

EXOcompact is a range of freely programmable controllers, fully compatible with other products in the EXO system. They can easily be integrated with EXOflex and EXO4 in large automation systems.

The range consists of eight different models with different I/O configuration, with or without internal display, and with different communication ports.

The programming is performed in EXOdesigner, the same development environment as for all other EXO controllers.

EXOcompact is in standard configuration intended for stand-alone use or as a controller in an EXO system with communication via RS485 (e.g. EXOline[®] or ModBus). With the addition of one or two option cards it will also fit into a TCP/IP and/or LON network.

EXOcompact can either be mounted on a DIN rail as standard or, with an additional mounting kit, in a front panel. The form factor of the casing is EURO norm, which makes it fit into a standard EURO norm cabinet.

For installations requiring an external display (HMI), EXOcompact is prepared with a connector for ED9200, ED9100 or E-DSP.

Key Features

- Freely programmable in EXOL[®], the EXO high level language.
- In designed Euro norm enclosure for DIN-rail or front panel mounting.
- I/O is connected with jackable screw connectors.
- Power supply 24VAC/DC with wide input voltage range.
- One galvanically insulated communication port for reliable communication.
- Real Time Clock (RTC) for accurate time control.
- Battery backup of Memory and RTC with easy replaceable button cell.
- 480 Kbytes application memory and non-volatile storage for calibration parameters.
- EXOreal operating system with multitasking in 64kB flash upgradeable PROM.
- Application program and real time operating system remotely upgradeable via communication port.
- Status indication via LEDs indicating Power on, Communication active and Battery status
- Variants with TCP/IP or LON Port.
- CE-marked according to: EN61000-6-3 (emission), EN61000-6-1 (immunity).
- Models with display:**
 - LCD display, 4*20 characters with background lighting for European, Cyrillic and Greek characters.
 - Keypad with seven keys for easy navigation in dialog tree structures, alarm handling and parameter settings/configuration.
 - Keys have tactile membrane switches with metal domes for distinct feeling and optimum performance.

Range of Models

The following overview is a list of the units that are described in the following chapters. Other units may exist. Please contact your nearest supplier or Regin for information on the current product range.

Single Port Models

I/O	EXOcompact Single Port Models:					
	C80-S	C80D-S	C150-S	C150D-S	C280-S	C280D-S
AI	2	2	4	4	4	4
DI	3	3	4	4	8	8
UI, (AI or DI selectable)					4	4
AO	1	1	3	3	5	5
DO	2	2	4	4	7	7
Sum I/O	8	8	15	15	28	28
Communication, RS485 port: Port 1: EXOline (built-in)	Yes	Yes	Yes	Yes	Yes	Yes
Internal display & keypad	No	Yes	No	Yes	No	Yes
24VDC output	Yes	Yes	Yes	Yes	Yes	Yes
Other features:						
Support for external terminal, ED9200, ED9100 & E-DSP (HMI)	Yes	No	Yes	No	Yes	No

Variants for ordering, communication ports:						
LON, L (gives an additional port)	C80L-S	C80DL-S	C150L-S	C150DL-S	C280L-S	C280DL-S
TCP/IP, T (replaces the RS485 port (#1))	C80T-S	C80DT-S	C150T-S	C150DT-S	C280T-S	C280DT-S

Dual Port Models

I/O	EXOcompact Models:			
	C152D-S	C282D-S	C152-S	C282-S
AI	4	4	4	4
DI	4	8	4	8
UI, (AI or DI selectable)		4		4
AO	3	5	3	5
DO	4	7	4	7
Sum I/O	15	28	15	28
Port 1: RS485 / galvanically insulated:	Yes/Yes	Yes/Yes	Yes/Yes	Yes/Yes
Port 2: RS485 / galvanically insulated:	Yes/No	Yes/No	Yes/No	Yes/No
Internal display & keypad	Yes	Yes	No	No
24VDC output (+C)	Yes	Yes	Yes	Yes
Other features:				
Support for external display, ED9200, ED9100 & E-DSP (HMI)	No	No	Yes	Yes

Variants for ordering, communication ports:	C152DT-S	C282DT-S
TCP/IP, T (replaces the RS485 Port 1)	Yes	Yes
Port 2: RS485 / galvanically insulated:	Yes/Yes	Yes/Yes

LON Port

The LON port is based on FT 3150 Smart Transceiver from Echelon (two-wire connection).

Suitable LonMark function profile is selected from EXOdesigner's library to match the external LON equipment function profile. The connection between the SNVTs of the function profile and the corresponding EXOL variables are predefined in a so-called .dpe file that is downloaded via the EXOLine port.

The selected function profile is loaded as an .apb file through the LON network. The accompanying variable description file (.xif file) is used by LonMaker for variable binding and integration purposes.

FT 3150 Neuron acts as a gateway out on the LON network.

A maximum of 62 SNVTs can be handled in the predefined function profiles.

The cable to use, max cable length, network building, terminations etc. should be performed according to directions from Echelon.

The LON technology and configuration of the LON port on EXOcompact is described in the document *LON in EXO Systems*.



Please observe that EXOcompact –S generation requires a different .apb file compared to non –S models.

Modem Port

Externally you can connect **Modem 56k small INT RS485** (Modem56kINT485) to Port #1, EXOline.

Modem 56k small INT RS485 consists of a modem, a line cable, an RS232 cable, an E-cable-RS232 and a *null modem adapter*.

When using the modem for EXOcompact and Corrigo E controllers, you can connect the controller and the modem directly with the included E-cable-RS232 and the *null modem adapter*. You do not need the RS232 cable.



E-cable-RS232



Null modem adapter

The Modem 56k small INT RS485 is delivered preconfigured to be used for EXOcompact and Corrigo E controllers with the communication speed 9600 bps. If you wish to use 2400 bps, or for some other reason need to reconfigure the modem, see the document *Accessories to EXO*.

External Display

ED9200 has an alphanumeric display with four lines, each with 20 characters. It can be used with both EXOflex and EXOcompact by using different connection interfaces. For EXOcompact/Corrigo E there are two cord sets available, one for 3 m and one for 10 m.

Alternatives to ED9200 are ED9100 and E-DSP. These are only intended for EXOcompact and Corrigo E. Also these have alphanumeric displays with four lines, each with 20 characters. There are two cable sets available, one for 3 m and one for 10 m.

Chapter 2 Technical Specifications

Environmental Specifications

EXOcompact may be used under the following conditions:

Operating temperature.....0 to +50°C
Storage temperature..... -20 to +70°C
Humidity (non-condensing)max 95 %

Enclosure Specifications

EXOcompact enclosure has the following properties:

CabinetEURO norm
Mounting DIN rail snap in
optional.....in front plate, use separate mounting kit
Protection class..... IP20 (cabinet mounting)
Plastic Polycarbonate, PC

Dimensions

A side-view of EXOcompact, with dimensions.

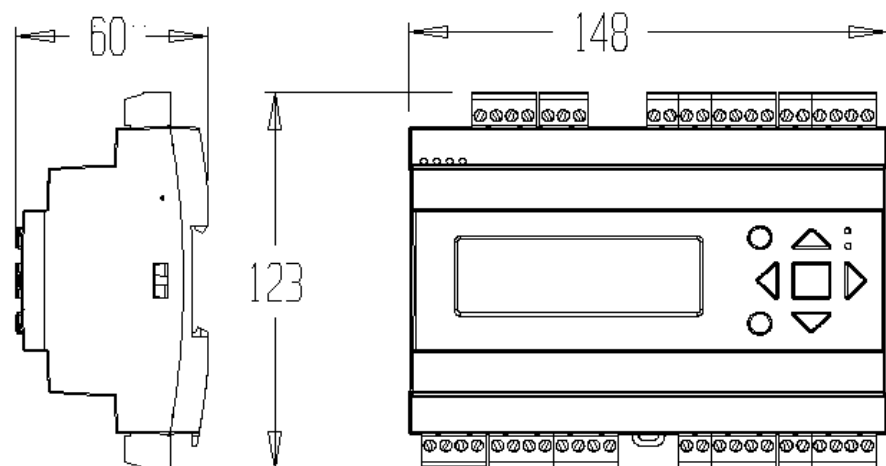

Electrical Specifications

Number and types of I/O for each model are found in Chapter 1:

Power Supply

Supply voltage..... 18-30 V AC or 20-30V DC
Current requirement..... 6 VA without load

CPU & Memory

Operating systemEXOreal
Conventional RAM memory 32 kB
Application RAM memory 480 kB
Battery backup of RAM, RTC..... 5 years
Battery monitoring..... status LED + software accessible
EEPROM with factory settings and calibration parameters Yes
Real-time clock (RTC) max ± 40 sec./month.

Battery Backup

Type.....Lithium, CR2032

Communication ports

Port 1

Type.....RS485
built-in protocol.....EXOline
other protocolscontact RegIn
Control signals, RS485 E
Speed configurable, 1200-28800 bps
standard 9600 bps
Galvanic isolation, common mode voltage..... max. 150 V

Port 2

Type.....RS485
built-in protocol.....EXOline
other protocolscontact RegIn
Control signals, RS485 E
Speed configurable, 300-28800 bps
standard 9600 bps
Galvanic isolation if two RS485 portsno
Galvanic isolation, common mode voltage (-T model only) max. 150 V

LON Port

CPU Neuron type 3150
RAM memory 8 kB
Connection..... 78 kbps FT 3150 Smart Transceiver, for two-wire cable
max cable length.... depending on bus topology and cable type, see <http://www.echelon.com>
connectors.....screw connector
lightning protection standardized spark gap on circuit card

Analog Inputs, AI

Basic ADC resolution 12 bit
Measurement range program selectable/channel
Temperature (PT1000) -50-+150°C
.. accuracy (excluding sensor) +0.4°C
Temperature (Ni1000 DIN) -40-+105°C
.. accuracy (excluding sensor) +0.4°C
Temperature (Ni1000 L&G)..... -40-+120°C
.. accuracy (excluding sensor) +0.4°C
Current..... 0-20 mA, requires external 10 Ohm shunt
.. accuracy depends on external shunt
Voltage 0-10 V

.. input resistance	10 MOhm
.. accuracy (% of full scale)	+0.15%
Voltage	0-200 mV
.. input resistance	10 MOhm
.. accuracy (% of full scale)	+0.15%

Conversion Time for all channels max 48 + n*48ms, where n is the number of active channels, including activated UI channels.

UI, Universal Inputs, AI or DI selectable

See AI or DI depending on selection, except for the below specific UI parameters:

Voltage	0-10V and 0-200 mV
.. input resistance	1 MOhm

Analog Outputs, AO

Basic DAC resolution	8 bit
Output level	0-10 V DC
Update cycle	300 ms
Max load	5 mA, short circuit proof

Digital Inputs, DI

Type	24VDC, floating contact, powered from 24VDC output, pin 4
Logic 0	0-5 V DC
input current at 0V	0 mA
input resistance	8 kOhm
Logic 1	12-24V DC
input current at 24V DC	3 mA
Frequency range	Normally 2 Hz. Max 50 Hz requires Task with cycle time 1 to
Shortest pulse length for detection (transient flag)	8 ms

24V DC output

Output voltage	24 V DC± 2V
Max load	0.1 A

Digital Outputs, DO type MOSFET

Output	24V AC or DC
Max continuous load	2 A
Max total load at terminal GDO (10) sourcing the power to DO	8 A
Update cycle	50 ms

Internal Display



Type	LCD, 4*20 characters with background lighting
Character set	European, Cyrillic, Greek. See also character table
Backlight	LED, yellow-green
Character matrix	5*8, 4.75 mm height

Indications

Status indications can be found in the upper left corner of the controller. For controllers with display, the alarm indication and change mode LEDs are located in the keypad area.



Status Indications

Designation	Color	Description
P1RxTx	Yellow /Green	Port 1, Receiving/Transmitting
P1RxTx (-T models)	Yellow /Green	EXOline, Receiving/Transmitting from TCP/IP card
P2RxTx	Yellow /Green	Port 2, Receiving/Transmitting
LAN (-T models)	Yellow /Green	Green: Link to other network equipment Flashing green: Network traffic Flashing yellow: For identifying
Serv (-L models)	Yellow	Service LED LON, commissioning
P/B (Power/Battery)	Green/Red	Power on / Battery error
	Red	Alarm indication
	Yellow	Change mode

Chapter 3 Connections



Generic general connection diagrams are shown below. For specific models see product sheets.

Single Port models

If DC Power Supply is used, connect + to terminal 1 and – to terminal 2.

Connections for EXOcompact C80x-S.

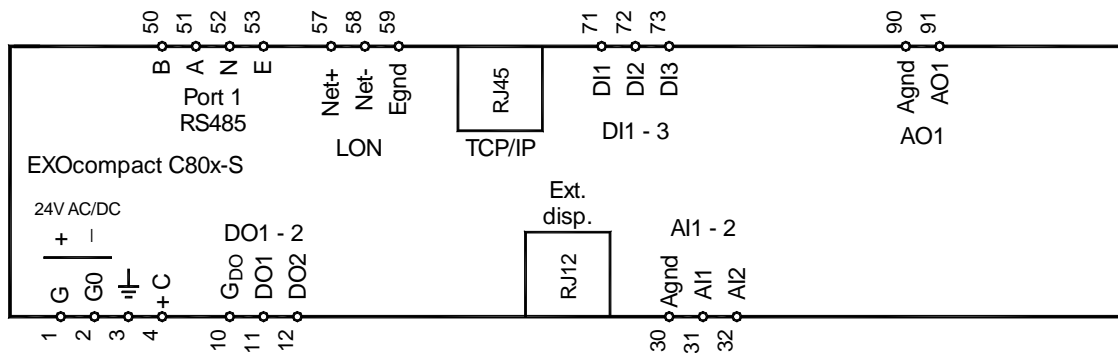

Connections for EXOcompact C150x-S.

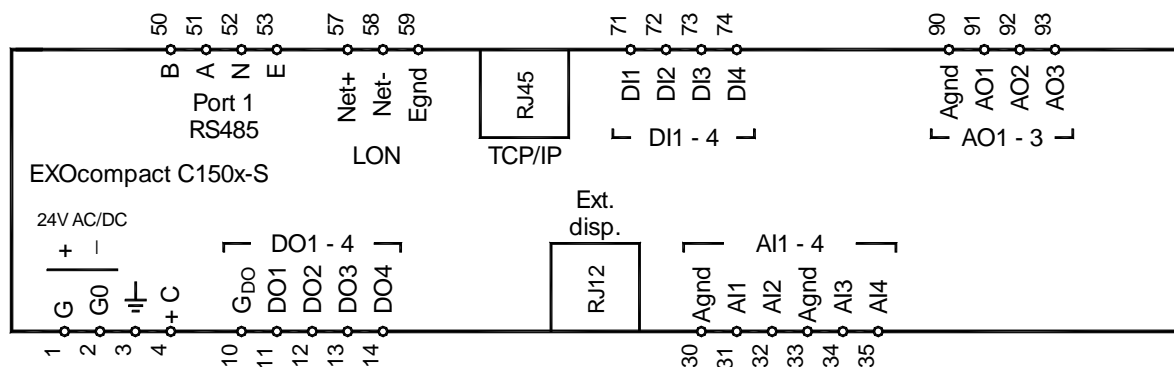

Connections for EXOcompact C280x-S.

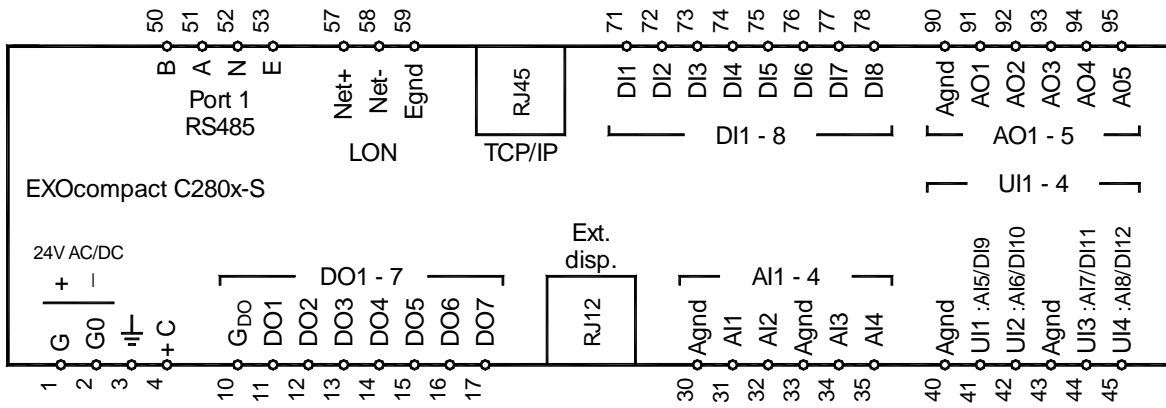

Dual Port models

Connections for EXOcompact C152x-S.

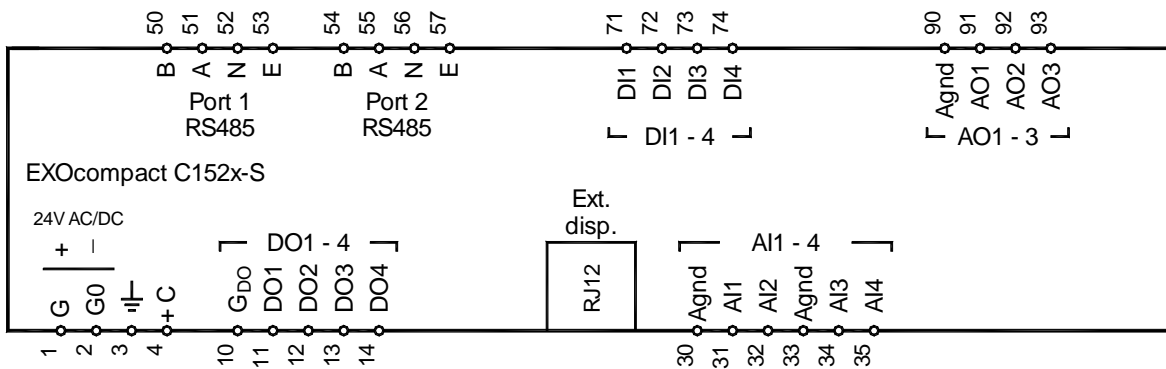

Connections for EXOcompact C152xT-S.

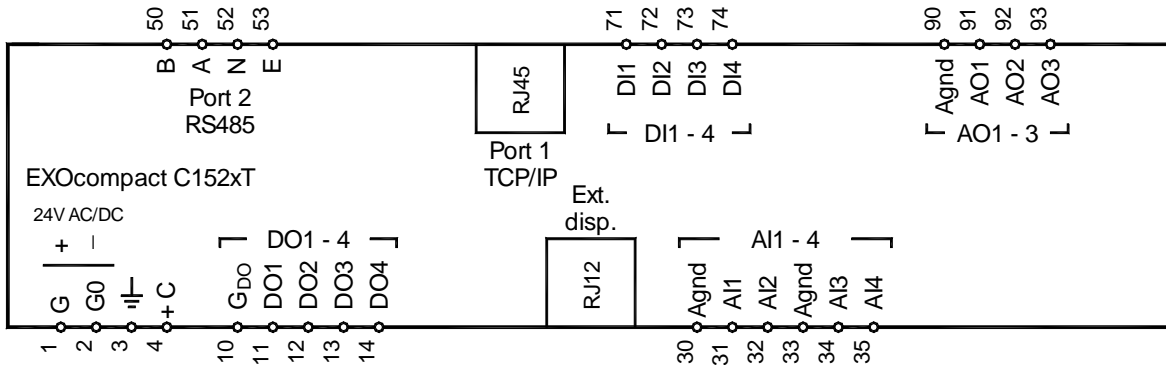

Connections for EXOcompact C282x-S.

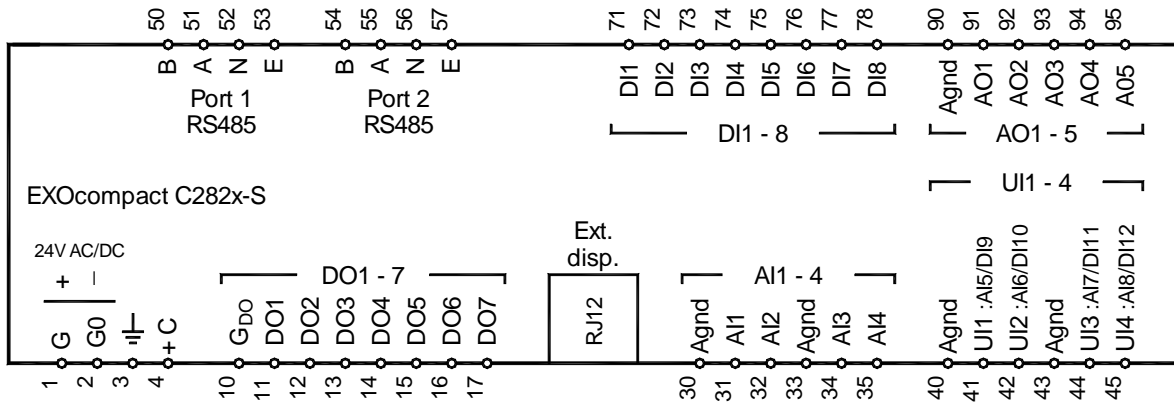

Connections for EXOcompact C282xT-S.

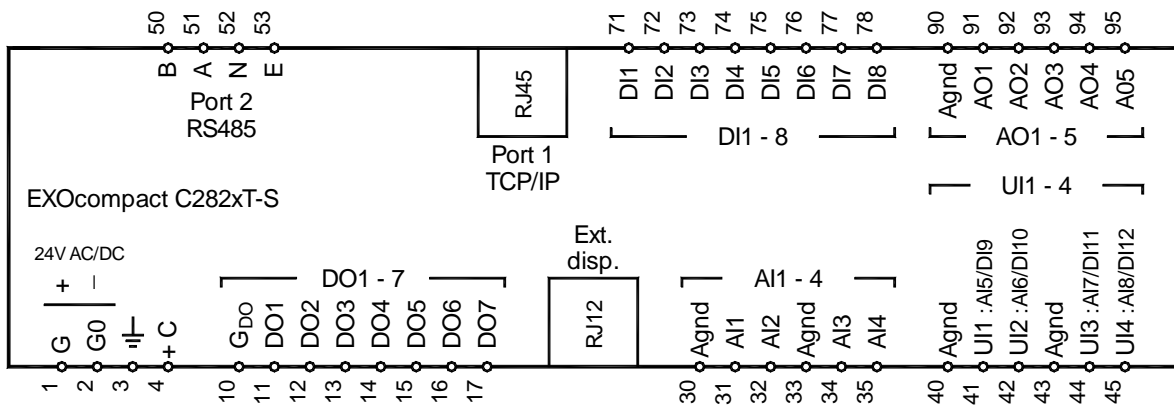

Chapter 4 Installation

General Connections

With AC Supply and Mixed Loads on DO

The general connections of EXOcompact with AC supply are illustrated in the figure below:

General Connections with AC Supply (EXOcompact C282XX-S)

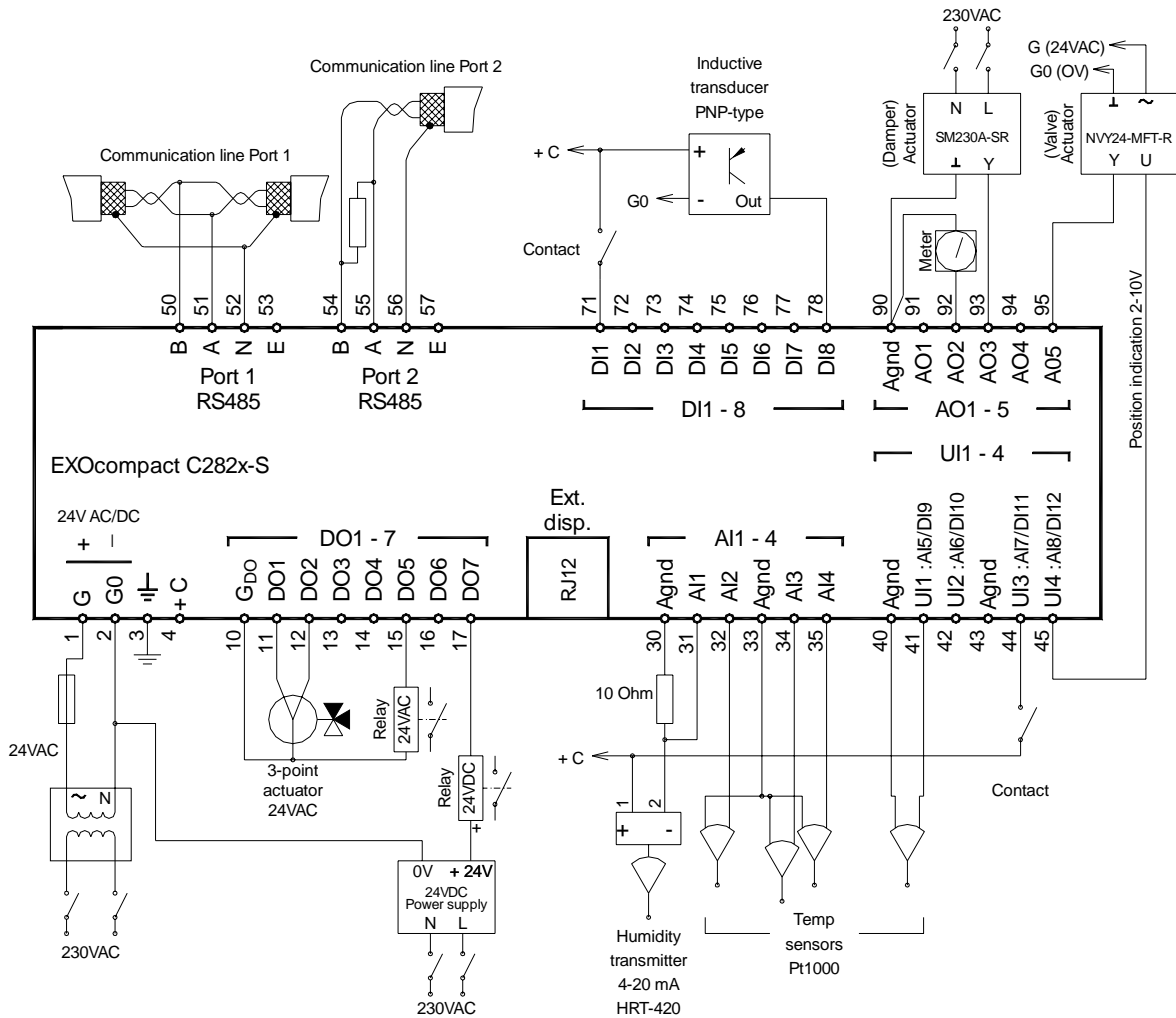

With DC Supply and Mixed Loads on DO

The general connections of EXOcompact with DC supply are illustrated in the figure below. For the rest of the connections, see the previous figure:

General Connections with DC Supply (EXOcompact C282XX-S)

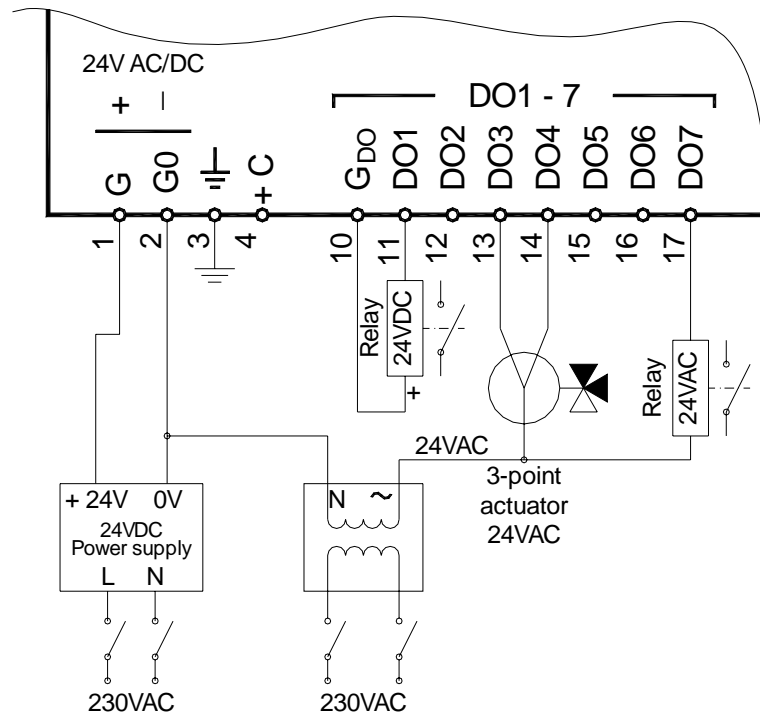

I/O Description

AC Power Supply

The 24V AC supply, typically a 230V/24V transformer, is connected to contacts **G0** (2) signal ground and **G** (1), phase. The **G0** (2) terminal should normally be connected to earth. The EMI earth (\perp) must be connected to the earth rail or similar to protect against disturbances. Each process connection has active transient protection, which is led to the EMI earth (\perp).

The **+C** output is used to power supply auxiliary equipment requiring 24VDC power.

DC Power Supply

The 24V DC supply, typically a stabilised power supply, is connected to the contacts - (2) and + (1). The - (2) terminal should normally be connected to earth. The EMI earth (\perp) must be connected to the earth rail or similar to protect against disturbances. Each process connection has active transient protection, which is led to the EMI earth (\perp).

AI Process Connections

The connection of two passive sensors like PT1000 and an active 2-wire transmitter is shown in the figure at the beginning of this chapter. Note that low level sensors are returned to the **Agnd**, high quality ground.

- This type of input is mainly intended for use with sensors using voltage outputs and resistance elements for measuring temperature.
- Voltage signals must be connected between the input and **Agnd**.
- A cable screen is recommended. It should be connected to the ground bar.
- External transmitters for 4-20 mA can be powered from a **+C** output. A fast fuse should be fitted in serial with the transmitter to protect the input from short circuits in the transmitter.
- All **Agnds** are internally linked to each other and to **G0**.

To attain maximum accuracy and according to specifications, each respective **Agnd** should be used as a reference for the measuring.

AO Process Connections

The AO terminals carry 0-10 V with reference to the **Agnd** terminal (= Internal Signal Ground). The outputs are internally powered. The figure shows the connection of a 24V AC powered control valve actuator, which is referenced to **G0**, and an example with a simple voltmeter which is referenced to **Agnd**.

- This type of output is mainly intended for use with damper motors, shunt valves, frequency inverters and other analog actuators for 0–10 V.
- Each output is current limited and short circuit proof.
- Normal, high-ohm loads are connected between the output and **Agnd**. Other types of loads for special applications with low-ohm loads are best connected between the output and **G0**. See the example with the Actuator that is connected to **G0**.
- All **Agnds** are internally linked to each other and to **G0** terminal.

DO Process Connections

The example shows actuators, AC relays and similar connected to **GDO** in one end. In the other end, an active triac output sources **G0** (-) to the load.

Standard 24 V DC DI

Potential free contacts and two wire pressure switches, proximity switches and similar are powered from the **+C** (4) terminal which supplies +24V DC.

- This type of inputs are used for reading off floating (potential free) contacts. They are active high.
- The external contact's one end is connected to the input and the other to **+C**. The **+C** output is current limited and short circuit proof.

EXOcompact Dual Port – Example Using Port 2 (Low Level EXOline)

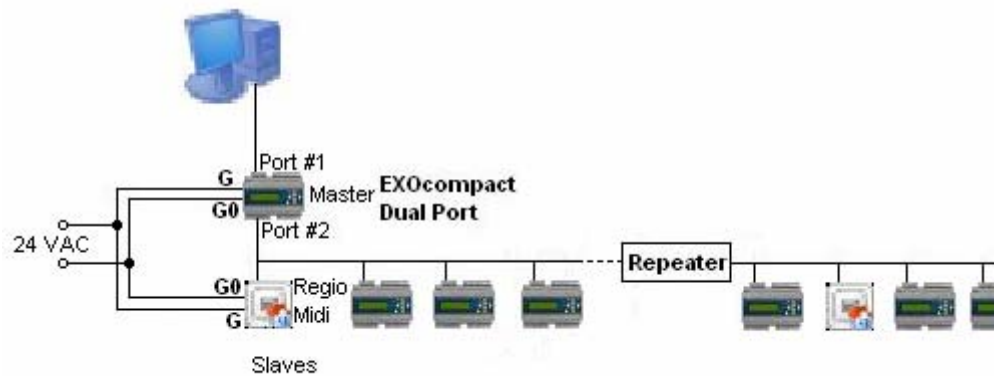

EXOcompact Dual Port C152D-S and C282D-S have an un-isolated communication port (Port #2), Low Level EXOline. Except for the isolation all other characteristics are compatible with EXOline and the two types could be mixed in a network without any problem.

If you connect two controllers (master – slave) with un-isolated communication ports, please observe the following demands:

- When using the same power supply for two controllers connected with un-isolated communication ports, you must connect G0 to G0 and G to G. They must not be cross-connected! See an example with EXOcompact Dual Port and Regio Midi in the above figure.
- The longest communication cable length is 300 m between un-isolated master/slave ports.
- The communication cable must be well separated from power cables and other possible interfering (EMI) cables.
- A maximum of 32 controllers is allowed on the same communication line without a repeater.
- A repeater with isolated power supply (e.g. Repeat485 from Regin) is recommended to prolong the communication distance and number of controllers.

Chapter 5 Maintenance and Service

Changing the Battery

When the battery indicator is lit, the battery for backup of program memory and the real-time clock has become too weak. The battery is replaced as described below. A backup capacitor saves the memory and keeps the clock running for at least 10 minutes after the power supply is removed. Thus, if battery replacement takes less than 10 minutes, there will be no need to reload the program and the clock will continue to run normally.

The replacement battery must be of the type CR2032.



This procedure requires knowledge of proper ESD protection; i.e. an earthed wristband must be used! How to lift off the cover can be found in chapter *Remove the Cover*.

Battery location.

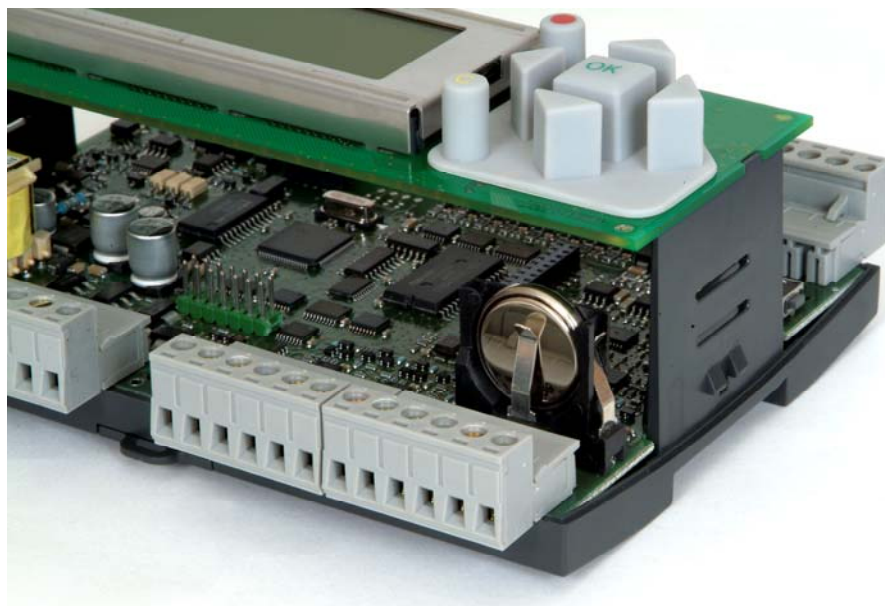

Grip the battery firmly with your fingers and lift it upwards until it rises from its holder.

Press the new battery firmly down into place. Note that to preserve correct polarity, the battery can only be inserted the “right way round”.

Resetting the Application Memory



This procedure may only be carried out by qualified resellers and requires advanced knowledge. The application will be permanently lost after this procedure.

To reset the processor's program memory (application programs), use the reset button accessed through the small hole on the right side of the unit. A tip is to use a paper-clip to access the reset button.

Accessing the reset button.

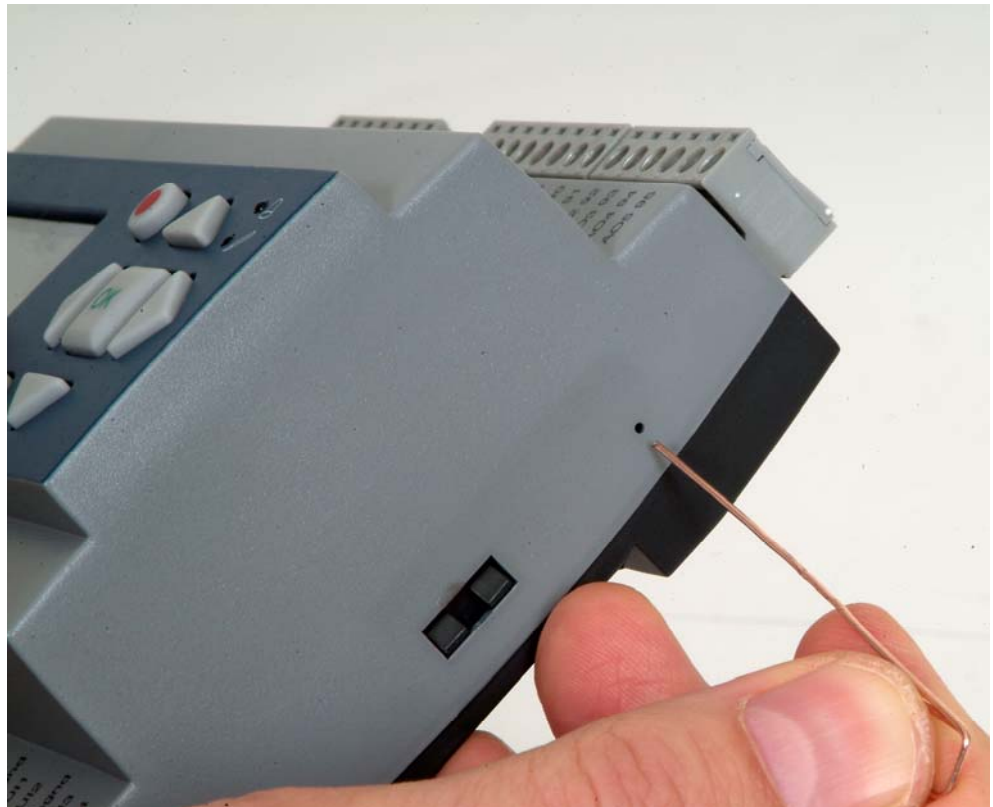

Updating EXOreal

The operating system is updated from Port 1, RS485 port or TCP/IP. Use EXOdesigner!

Removing the Cover



This procedure requires knowledge of proper ESD protection; i.e. an earthed wristband must be used!

Tools needed: 2 mm screwdriver.

Begin with hooking off the controller from the DIN rail by pressing the DIN lock mechanism down, see picture below.

Press the lock down.



Tilt the lower part out from the rail and hook off the controller.



Bend out and lift off the cover.

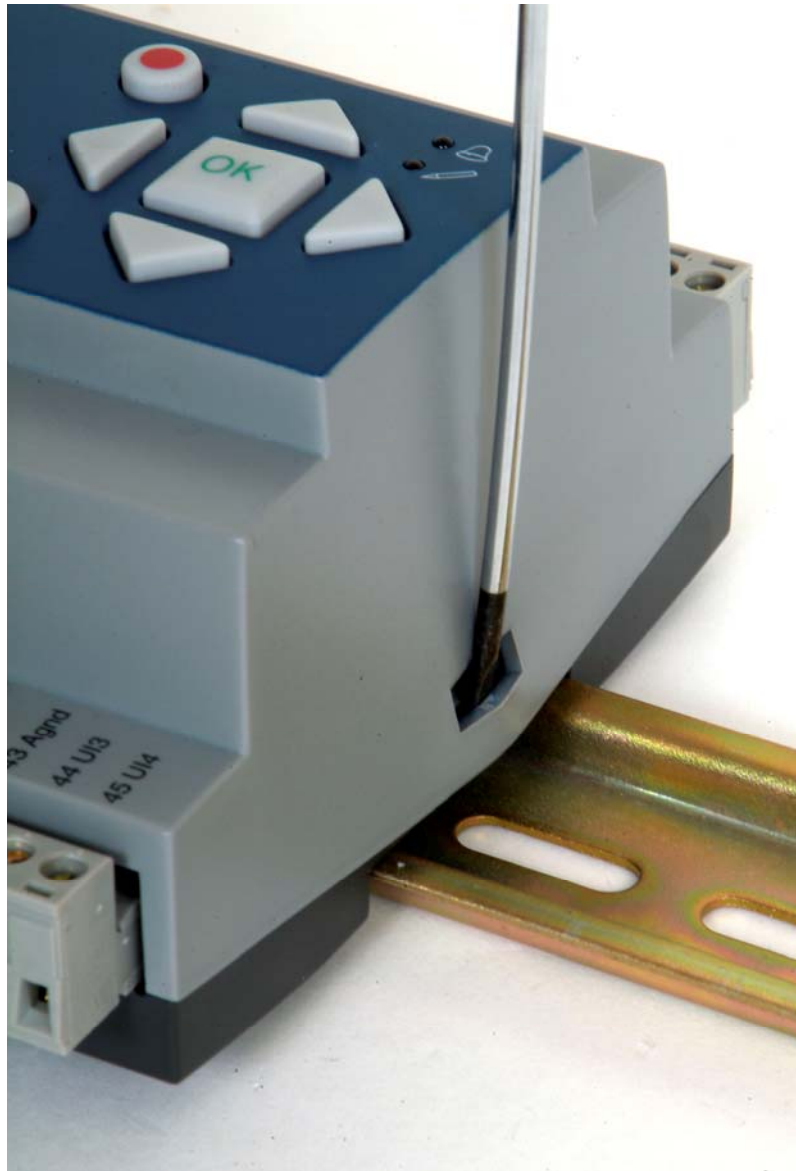

Chapter 6 External Display, ED9200



Functions

ED9200, external display, is a separate unit for display and configuration that can be connected either to an EXOcompact/Corrigo E or to an EXOflex via two different electrical interfaces.



- The dialog window, which is an LCD display with background lighting, has 4*20 characters. The character set is European/Cyrillic.
- Environmental resistant overlay with a keypad containing navigation and entry keys with click feeling.
- Software controlled alarm LED and indication of communication and power supply.
- Mounting can be made on panel or the like.
- With a sealant kit, the sealing class will be IP65 when mounted on a panel or the like.
- About connection to EXOflex, see the EXOflex documentation.



When ED9200 is connected to EXOcompact/Corrigo E, functions like software controlled view angle, background lighting, and buzzer are missing. To get these properties you have to connect the display to EXOflex! In addition to that, the communication distance is limited to maximum 10 m when connection is made to EXOcompact. The corresponding distance for EXOflex is 200 m.

Indications

The indication LEDs have the following functions:

Designation	Function	Color
P	Power supply.	Green
C	Communication.	Green
	There is one or more unacknowledged alarm(s).	Flashing red
	There is one or more remaining, acknowledged alarm(s).	Fixed red
	You are in a dialog box where it is possible to switch to change mode.	Flashing yellow
	Change mode.	Fixed yellow

Controller Requirements

The handling of ED9200 in EXOcompact/Corrigo E requires EXOreal 2.8-1-29 or later.

Specifications

Power supply via communication cableinternal from EXOcompact/Corrigo E

Display 4*20 alphanumeric characters, LCD
 character height4.75 mm
 background lighting..... yes, save mode/active mode

Sealing class IP41 in basic design, IP65 as option

Connection cable..... 3 different types with RJ12 fast connector
 EK10 1.5 m
 EK12 3 m
 EK14 10 m
 Maximum cable length for EXOcompact/Corrigo E is 10 m.

Connections

Connection of cable EK12 or EK14 to EXOcompact/Corrigo E is made according to the below picture. At the bottom of EXOcompact, there is an RJ12 modular jack for fast connection.

The connection of cable EK12 or EK14 to ED9200 is illustrated in the figure below. The right part of the connection instruction shows how to connect Corrigo E/ EXOcompact.

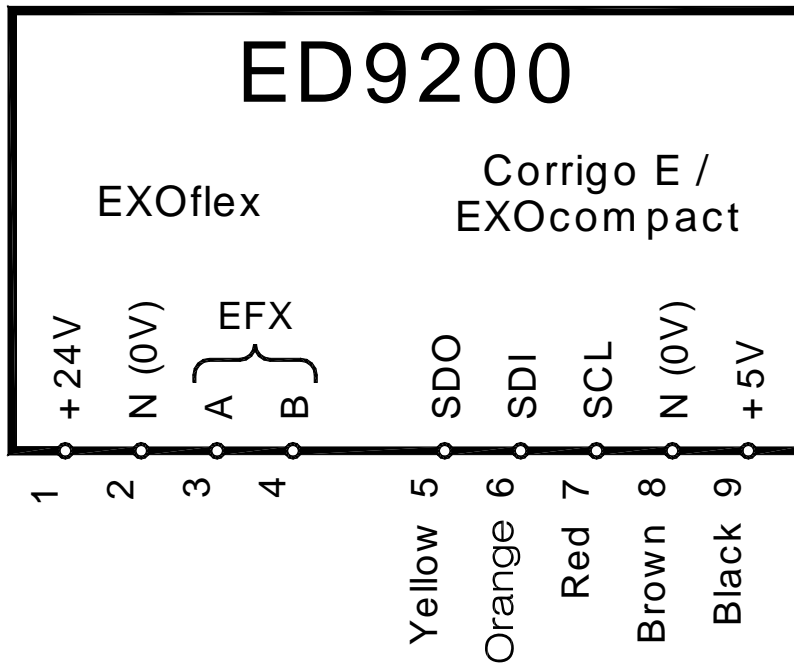

Door Mounting

Mounting in cabinet door is made by using the supplied drill template, screws and cable inlet.

Drill template for door mounting (not to scale).

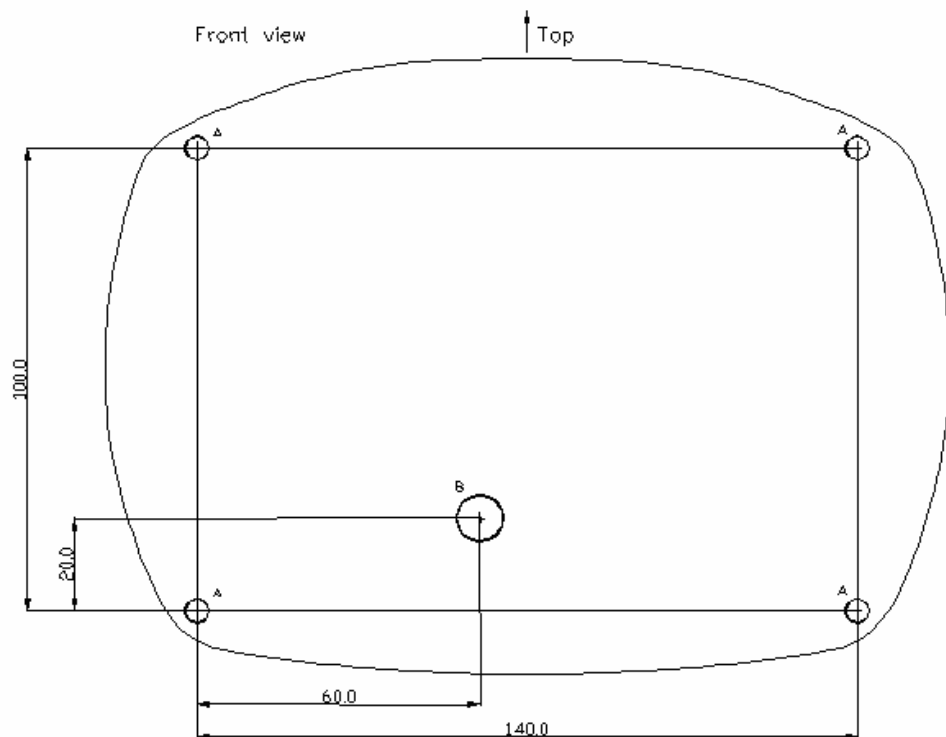

Drill: A = $\varnothing 5.0$ (4x). For self-tapping screw RXK-Z ST 4.2 x 13 (dia 4.2 x 13) or similar.
 B = $\varnothing 10.0$ or other hole dia depending on cable size. Use grommet to protect cable.

Chapter 7 External Display, ED9100



Functions

ED9100, external display, is a separate unit for display and configuration that can be connected either to an EXOcompact or a Corrigo E.



- The dialog window, which is an LCD display with background lighting, has 4*20 characters. The character set is European/Cyrillic.
- Environmental resistant overlay with a keypad containing navigation and entry keys with click feeling
- Software controlled alarm LED and indication of communication and power supply.
- Mounting can be made on panel or the like.
- With a sealant kit, the sealing class will be IP65 when mounted on a panel or the like.
- ED9100 is available in two variants: ED9100-3 is delivered with 3 m connection cable, and ED9100-10 with 10 m connection cable.



ED9100 can not be connected to EXOflex. Use ED9200 if you wish to connect a display to EXOflex.

Indications

The indication LEDs have the following functions:

Designation	Function	Color
P	Power supply.	Green
C	Communication.	Green
	There is one or more unacknowledged alarm(s).	Flashing red
	There is one or more remaining, acknowledged alarm(s).	Fixed red
	You are in a dialog box where it is possible to switch to change mode.	Flashing yellow
	Change mode.	Fixed yellow

Specifications

Power supply via communication cable	internal from EXOcompact
Display	4*20 alphanumeric characters, LCD
character height	4.75 mm
background lighting.....	yes, save mode/active mode
Sealing class	IP41 in basic design, IP65 as option
Connection cable	2 different types with RJ12 fast connector
ED9100-3 (corresponds to EK12)	3 m
ED9100-10 (corresponds to EK14)	10 m
Maximum cable length is 10 m.	

Connections & Mounting

See ED9200.

Chapter 8 External Display, E-DSP



Functions

E-DSP is a separate unit for display and configuration that is designed to be connected to EXOcompact or Corrigo E.



- The dialog window, which is an LCD display with background lighting, has 4*20 characters. The character set is European/Cyrillic.
- The keypad contains buttons with click feeling for navigation and configuration.
- Software controlled alarm LED and indication of configuration mode.
- Mounting can be done directly on a wall or on a wall socket.
- E-DSP is available in two variants: E-DSP-3 is delivered with 3 m connection cable, and E-DSP-10 with 10 m connection cable.



E-DSP can not be connected to EXOflex. Use ED9200 if you wish to connect a display to EXOflex.

Indications

The indication LEDs have the following functions:

Designation	Function	Color
	There is one or more unacknowledged alarm(s).	Flashing red
	There is one or more remaining, acknowledged alarm(s).	Fixed red
	You are in a dialog box where it is possible to switch to change mode.	Flashing yellow
	Change mode.	Fixed yellow

Specifications

Power supply via communication cable..... internal from EXOcompact

Display 4*20 alphanumeric characters, LCD
character height 4.75 mm
background lighting yes, save mode/active mode

Sealing class IP41

Connection cable 2 different types with RJ12 fast connector
E-DSP-3 (corresponds to EK12) 3 m
E-DSP-10 (corresponds to EK14) 10 m
Maximum cable length is 10 m.

Connections

See ED9200.

Mounting

On panel, wall, or 60 mm device box.

Chapter 9 Appendix

The EMC and LVD Directive

As of January 1st 1996, all electric/electronic products must be CE marked on delivery from the manufacturer and they must comply with certain requirements specified in the **EMC** and **LVD Directive**. The directives are issued by the EU commission.

The **EMC (ElectroMagnetic Compatibility)** directive describes the ability of a product to operate satisfactorily within its environment without disturbances. The **LVD (Low Voltage Directive)** directive mainly concerns electrical safety.

The EMC and LVD directives apply to **all** electric/electronic apparatus, systems and installations.

Declaration of Conformity

EMC

Units specified in this manual are CE marked and approved according to the following Generic EMC standards:

- EN61000-6-1 (immunity)
- EN61000-6-3 (emission)

LVD

Units specified in this manual are CE marked and approved according to the LVD directive.



Note that external power supplies generating 24V for EXO controllers must be CE marked as SELV (Safety Extra Low Voltage) or PELV (Protected Extra Low Voltage) power supplies.

Index

A

- AI 10
- AI Process Connections 18
- Analog inputs 10
- Analog outputs 11
- AO 11
- AO Process connections 18

B

- Battery 10, 20
- Battery backup 10
- Battery change 20

C

- Changing the battery 20
- Commissioning 16
- Communication ports 10
 - LON port 7
 - Modem port 8
 - Port 1 10
 - Port 2 10
- Communication ports
 - LON port 10
- Connections 13
 - AI 18
 - AO 18
 - DI 18
 - Display 25
 - DO 18
 - General 16
- Cover, remove 22
- CPU 10

D

- DC output 24V 11
- Declaration of Conformity 31
- Description, General 5
- DI 11
- DI Process connections 18
- Digital inputs 11
- Digital outputs
 - MOSFET 11
- Disclaimer 2
- Display
 - Connections 25
 - Door mounting 26
 - Internal 11
- DO
 - MOSFET 11
 - Process connections 18

- Door mounting
 - Display 26
- Dual Port
 - Low Level EXOline 19

E

- ED9100 8, 27
 - Functions 27
 - Indications 27
 - Specifications 28
- ED9200 24
 - Functions 24
 - Indications 25
 - Specifications 25
- E-DSP 8, 29
 - Functions 29
 - Indications 30
 - Mounting 30
 - Specifications 30
- EMC 31
- EMC and LVD directive 31
- EMC and LVD Directives 31
- EXOreal, update 21
- External display 8
 - ED9100 27
 - ED9200 24
- External Display
 - E-DSP 29

F

- Functions
 - ED9100 27
 - ED9200 24
 - E-DSP 29

G

- General connections 16

I

- I/O description 17
- Indications
 - ED9100 27
 - ED9200 25
 - E-DSP 30
- Inputs
 - Analog 10
 - Digital 11
 - Universal 11
- Installation 16
- Internal display 11

L

LED indication 12
LON port 7
LON-port 10
LVD 31

M

Maintenance and Service 20
Memory 10
Memory reset 21
Models, Range 6
Modem port 8
MOSFET DO 18
Mounting
 E-DSP 30

N

Neuron 7

O

Outputs
 +C 17
 24 V DC 11
 Analog 11
 Digital, type MOSFET 11

P

Port 1 10

Port 2 10
Power supply 10
 AC powered 17
 DC powered 17

R

Range of models 6
Removing the Cover 22
Reset the processor's memory 21
Resetting memory 21

S

Service 20
Shell, remove 22
SNVT 7
Specifications 9
 Dimensions 9
 ED9100 28
 ED9200 25
 E-DSP 30
 Electrical 10
 Enclosure 9
 Environmental 9
 LED indications 12
Standard 24V DC Digital Inputs 18
Status indication, LED 12

U

UI 11
Universal inputs 11
Updating EXOreal 21